

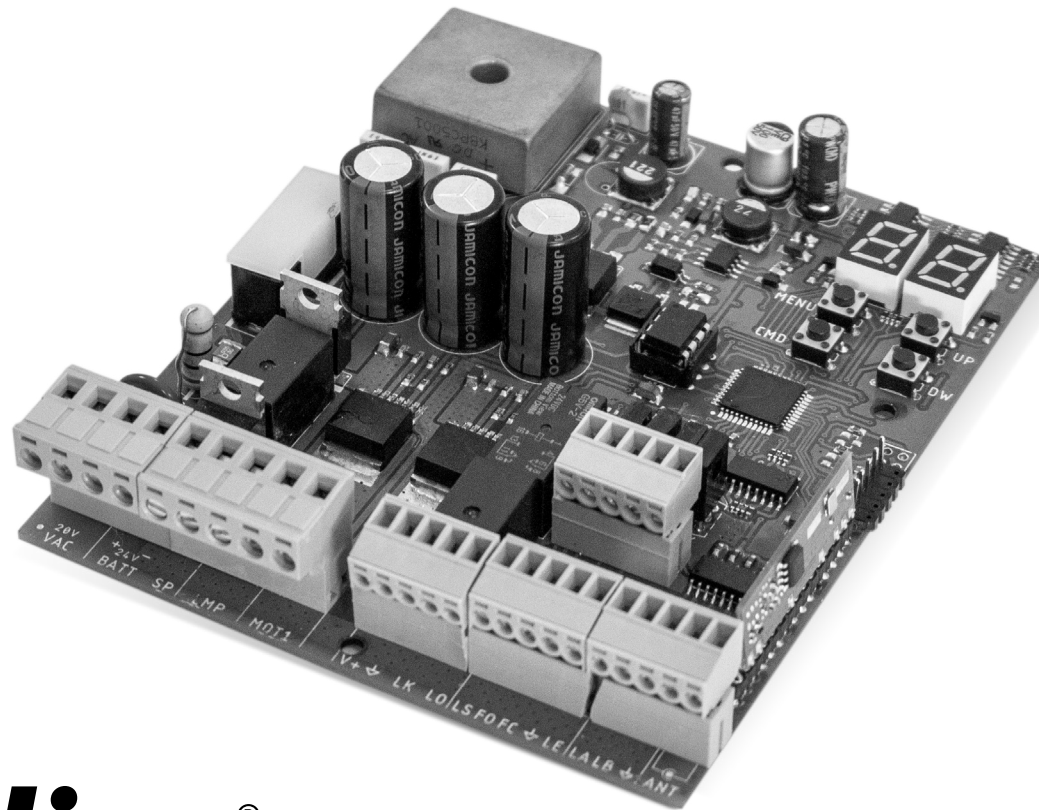

MC60





USER'S AND INSTALLER'S MANUAL



01. SAFETY INSTRUCTIONS	3A
02. CONTROL BOARD	
CHARACTERISTICS	5B
CONNECTORS	6A
BUTTONS AND LEDs	6B
03. CONNECTION SCHEME	
SLIDING GATES [SC]	7
SECTIONAL DOORS [SE]	8
BARRIERS [BR]	9
AUTOMATIC BOLLARDS [PL]	10
MASTER-SLAVE	11
04. INSTALLATION	
BASE INSTALLATION PROCESS	12A
REMOTE CONTROLS	12B
FUNCTIONS	13A
EXCLUSIVE FACTORY VALUES	13A
"P" MENUS	13B
"E" MENUS	14A
05. PROGRAMMING "P"	
P0-COURSE PROGRAMMING	14B
P1-SLOWDOWN TIME ADJUSTMENT	15A
P2-SETTING DOWN TIME	15A
P3-PEDESTRIAN COURSE TIME	15B
P4-PAUSE TIME	15B
P5-PHOTOCELLS 1 PROGRAMMING	16A
P6-PHOTOCELLS 2 PROGRAMMING	16B
P7-OPERATING LOGIC	16B
P8-FLASHING LIGHT	17A
P9-REMOTE PROGRAMMING	17A
06. PROGRAMMING "E"	
E0-HUMAN PRESENCE	17B
E1-SOFT START	18A
E2-COURTESY LIGHT TIME	18A
E3-FOLLOW ME	18B
E4-COURSE TIME ADJUSTMENT	18B

E5-BRAKE/LOCK/PUSH	19A
E6-SLOWDOWN SPEED	19A
E7-MANUEVERS COUNTER	19B
E8-RESET - RESET FACTORY VALUES	20
E9-RGB OUTPUT	20
07. DISPLAY	
DISPLAY INDICATIONS	21
08. CONNECTION SCHEME	
CONNECTIONS MAP	22

ATTENTION:

	<p>This product is certified in accordance with European Community (EC) safety standards.</p>
	<p>This product complies with Directive 2011/65/EU of the European Parliament and of the Council, of 8 June 2011, on the restriction of the use of certain hazardous substances in electrical and electronic equipment and with Delegated Directive (EU) 2015/863 from Commission.</p>
 	<p>(Applicable in countries with recycling systems). This marking on the product or literature indicates that the product and electronic accessories (eg. Charger, USB cable, electronic material, controls, etc.) should not be disposed of as other household waste at the end of its useful life. To avoid possible harm to the environment or human health resulting from the uncontrolled disposal of waste, separate these items from other types of waste and recycle them responsibly to promote the sustainable reuse of material resources. Home users should contact the dealer where they purchased this product or the National Environment Agency for details on where and how they can take these items for environmentally safe recycling. Business users should contact their vendor and check the terms and conditions of the purchase agreement. This product and its electronic accessories should not be mixed with other commercial waste.</p>
	<p>This marking indicates that the product and electronic accessories (eg. charger, USB cable, electronic material, controls, etc.) are susceptible to electric shock by direct or indirect contact with electricity. Be cautious when handling the product and observe all safety procedures in this manual.</p>

GENERAL WARNINGS

- This manual contains very important safety and usage information. very important. Read all instructions carefully before beginning the installation/usage procedures and keep this manual in a safe place that it can be consulted whenever necessary.
- This product is intended for use only as described in this manual. Any other enforcement or operation that is not mentioned is expressly prohibited, as it may damage the product and put people at risk causing serious injuries.
- This manual is intended firstly for specialized technicians, and does not invalidate the user's responsibility to read the "User Norms" section in order to ensure the correct functioning of the product.
- The installation and repair of this product may be done by qualified and specialized technicians, to assure every procedure are carried out in accordance with applicable rules and norms. Nonprofessional and inexperienced users are expressly prohibited of taking any action, unless explicitly requested by specialized technicians to do so.
- Installations must be frequently inspected for unbalance and the wear signals of the cables, springs, hinges, wheels, supports and other mechanical assembly parts.
- Do not use the product if it is necessary repair or adjustment is required.
- When performing maintenance, cleaning and replacement of parts, the product must be disconnected from power supply. Also including any operation that requires opening the product cover.
- The use, cleaning and maintenance of this product may be carried out by any persons aged eight years old and over and persons whose physical, sensorial or mental capacities are lower, or by

persons without any knowledge of the product, provided that these are supervision and instructions given by persons with experienced in terms of usage of the product in a safe manner and who understands the risks and dangers involved.

- Children shouldn't play with the product or opening devices to avoid the motorized door or gate from being triggered involuntarily.

WARNINGS FOR TECHNICIANS

- Before beginning the installation procedures, make sure that you have all the devices and materials necessary to complete the installation of the product.
- You should note your Protection Index (IP) and operating temperature to ensure that is suitable for the installation site.
- Provide the manual of the product to the user and let them know how to handle it in an emergency.
- If the automatism is installed on a gate with a pedestrian door, a door locking mechanism must be installed while the gate is in motion.
- Do not install the product "upside down" or supported by elements do not support its weight. If necessary, add brackets at strategic points to ensure the safety of the automatism.
- Do not install the product in explosive site.
- Safety devices must protect the possible crushing, cutting, transport and danger areas of the motorized door or gate.
- Verify that the elements to be automated (gates, door, windows, blinds, etc.) are in perfect function, aligned and level. Also verify if the necessary mechanical stops are in the appropriate places.
- The central must be installed on a safe place of any fluid (rain, moisture, etc.), dust and pests.
- You must route the various electrical cables through protective tubes, to protect them against mechanical exertions, essentially

on the power supply cable. Please note that all the cables must enter the central from the bottom.

- If the automatism is to be installed at a height of more than 2,5m from the ground or other level of access, the minimum safety and health requirements for the use of work equipment workers at the work of Directive 2009/104/CE of European Parliament and of the Council of 16 September 2009.
- Attach the permanent label for the manual release as close as possible to the release mechanism.
- Disconnect means, such as a switch or circuit breaker on the electrical panel, must be provided on the product's fixed power supply leads in accordance with the installation rules.
- If the product to be installed requires power supply of 230Vac or 110Vac, ensure that connection is to an electrical panel with ground connection.
- The product is only powered by low voltage safety with central (only at 24V motors)

WARNINGS FOR USERS

- Keep this manual in a safe place to be consulted whenever necessary.
- If the product has contact with fluids without being prepared, it must immediately disconnect from the power supply to avoid short circuits, and consult a specialized technician.
- Ensure that technician has provided you the product manual and informed you how to handle the product in an emergency.
- If the system requires any repair or modification, unlock the automatism, turn off the power and do not use it until all safety conditions have been met.
- In the event of tripping of circuits breakers or fuse failure, locate the malfunction and solve it before resetting the circuit breaker or replacing the fuse. If the malfunction is not repairable by

consult this manual, contact a technician.

- Keep the operation area of the motorized gate free while the gate is in motion, and do not create strength to the gate movement.
- Do not perform any operation on mechanical elements or hinges if the product is in motion.

RESPONSABILITY

- Supplier disclaims any liability if:
 - Product failure or deformation result from improper installation use or maintenance!
 - Safety norms are not followed in the installation, use and maintenance of the product.
 - Instructions in this manual are not followed.
 - Damaged is caused by unauthorized modifications
 - In these cases, the warranty is voided.

MOTORLINE ELECTROCELOS SA.

Travessa do Sobreiro, nº29
4755-474 Rio Côvo (Santa Eugénia)
Barcelos, Portugal

SYMBOLS LEGEND:



• Important safety notices



• Useful information



• Programming information



• Potentiometer information



• Connectors information



• Buttons information

The **MC60** is a control board with built-in radio control system, developed for the automation of sliding, sectional gates, barriers or 24V electromechanical bollard.

• Power Supply	20 Vac
• Flashing light's output	24VDC 4W Max.
• RGB Flashing light's output	24Vdc 100mA Max.
• Motor's output	24Vdc 180W Max.
• Auxiliary accessories output	24V DC 8 W Max.
• Security and BT remote controls	24V DC
• Working temperature	-25°C to + 55°C
• Incorporated Radio Receptor	433,92 Mhz
• OP remote controls	12bits or Rolling Code
• Maximum Memory Capacity	100 (full opening) - 100 (pedestrian opening)
• Control Board Dimensions	130x107 mm
• Fuse	8AL 250V

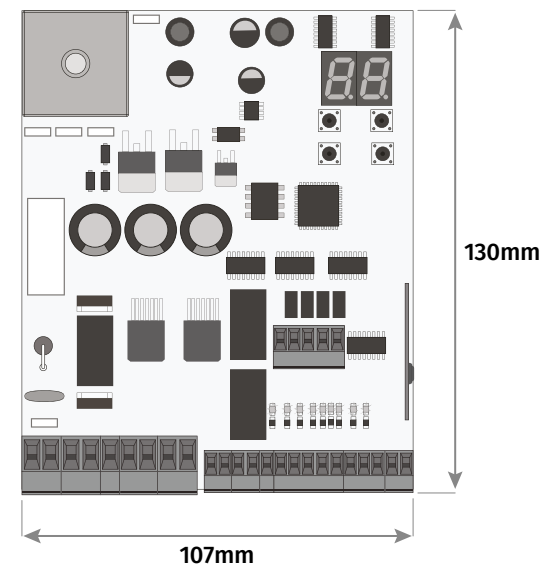

02. CONTROL BOARD

CONNECTORS

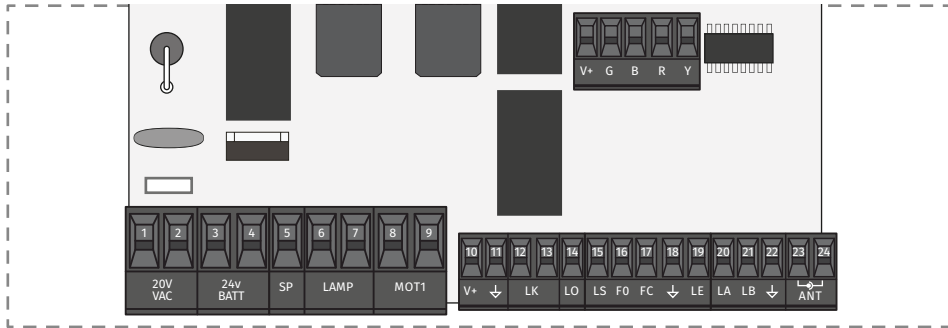

VAC	01 • Power Supply Input - 20Vac 02 • Power Supply Input - 20Vac
BATT	03 • 24Vdc Input for Emergency Battery 24V + max 7Ah 04 • COM Input (Solar Panel ou Emergency Battery) 05 • 24Vdc Input for Solar Panel (28V max. 30W)
LAMP	06 • 24Vdc Flashing light's Output (max 4W) 07 • 0V Flashing light's Output
MOT1	08 • 24Vdc Motor Output (max 180W) 09 • 24Vdc Motor Output (max 180W)
V+ ↓	10 • 24Vdc power supply output for accessories (max 8W) 11 • 0V power supply output for accessories
LK	12 • 24Vdc Electric Lock Output (max 12W) 13 • 0V Electric Lock Output
LO	14 • Total Opening Input (NO)
LS	15 • Pedestrian Opening Input (NO)
FO	16 • Closing limit-switch input
FC	17 • Opening limit-switch input
↓	18 • Common
LE	19 • Exterior Photocells (NC)
LA	20 • Interior Photocells (NC)
LB	21 • NC input for emergency device
↓	22 • Common
ANT	23 • Antenna 24 • GND

02. CONTROL BOARD

BUTTONS AND LEDs

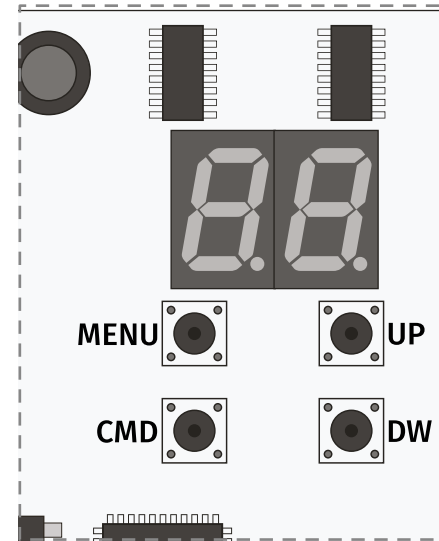

- MENU** • Access the Menu
- CMD** • Remote controls programmation
- UP** • Navigate through menus/values
- DW** • Navigate through menus/values

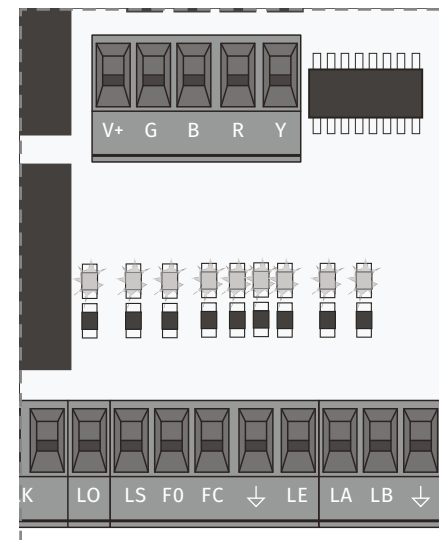

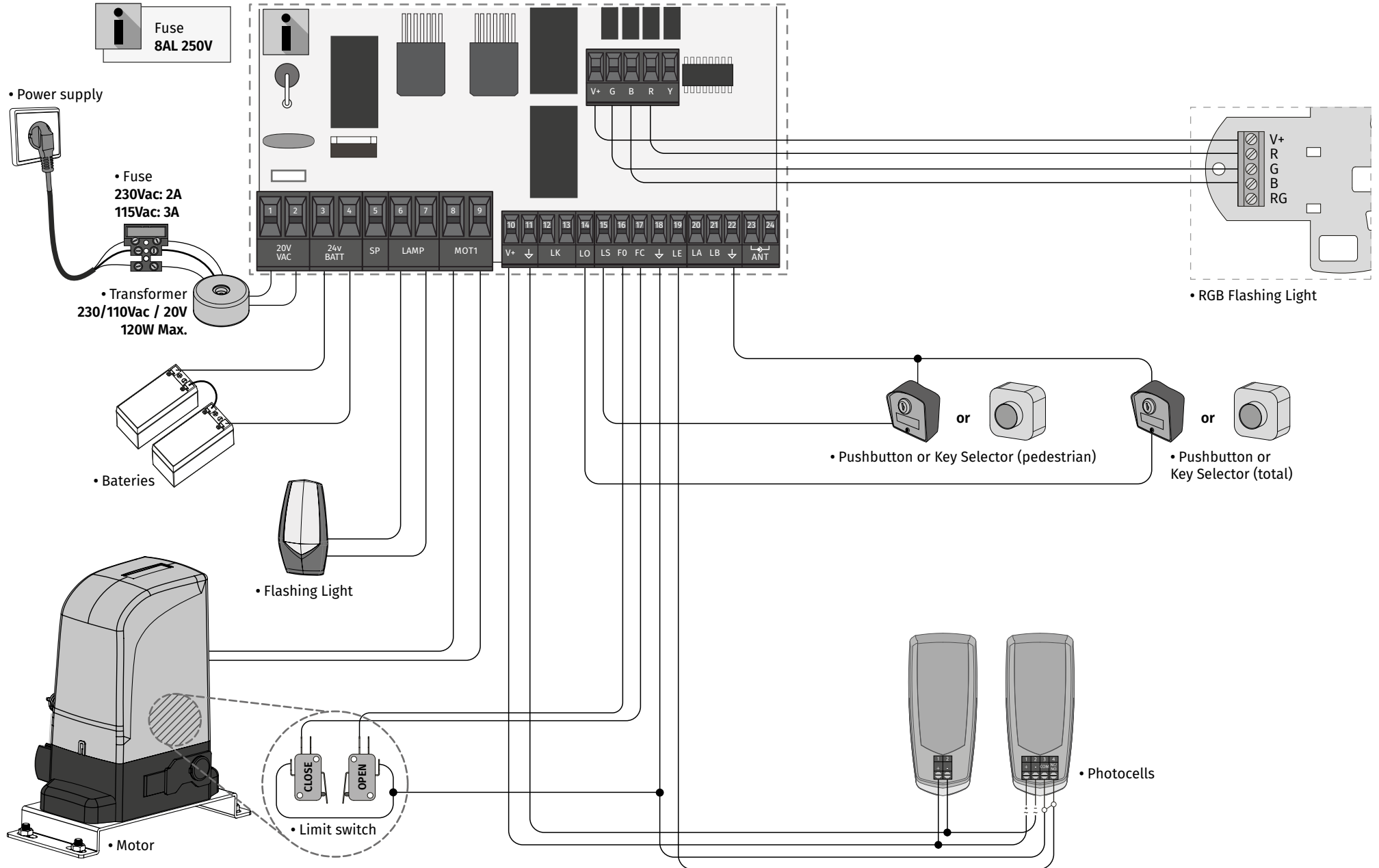

- LO** • LED ON when total opening input is active
- LS** • LED on when the pedestrian opening input is active
- FO** • LED OFF when the opening limit switch is active
- FC** • LED OFF when closing limit switch is active
- LE** • LED OFF when the signal from the exterior photocells is interrupted
- LA** • LED OFF when the signal from the interior photocells is interrupted
- LB** • LED OFF when the safety button is active
- BT** • LED ON when the battery is connected upside down
- VDD** • LED ON when power is supplied to the microcontroller

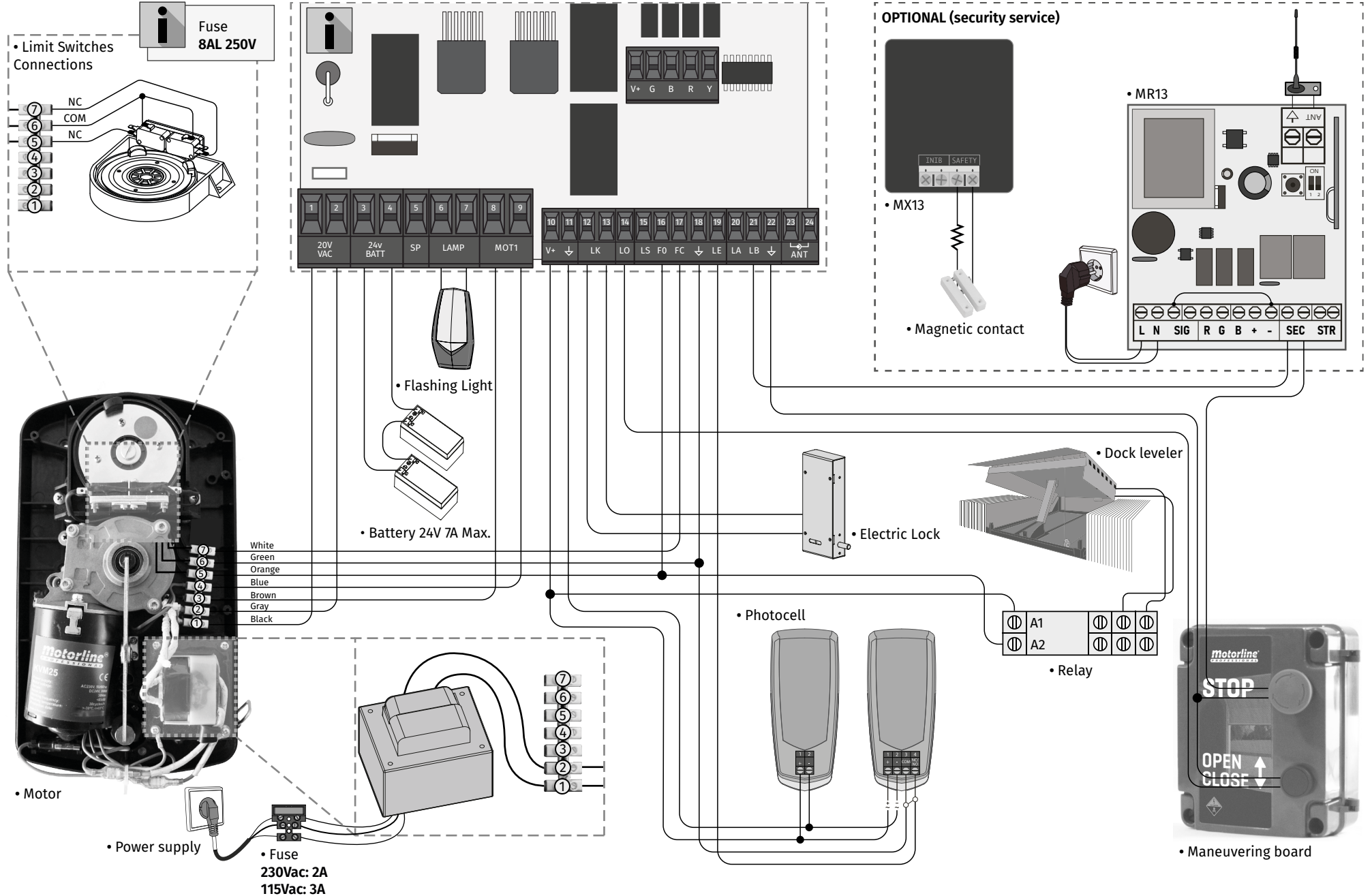

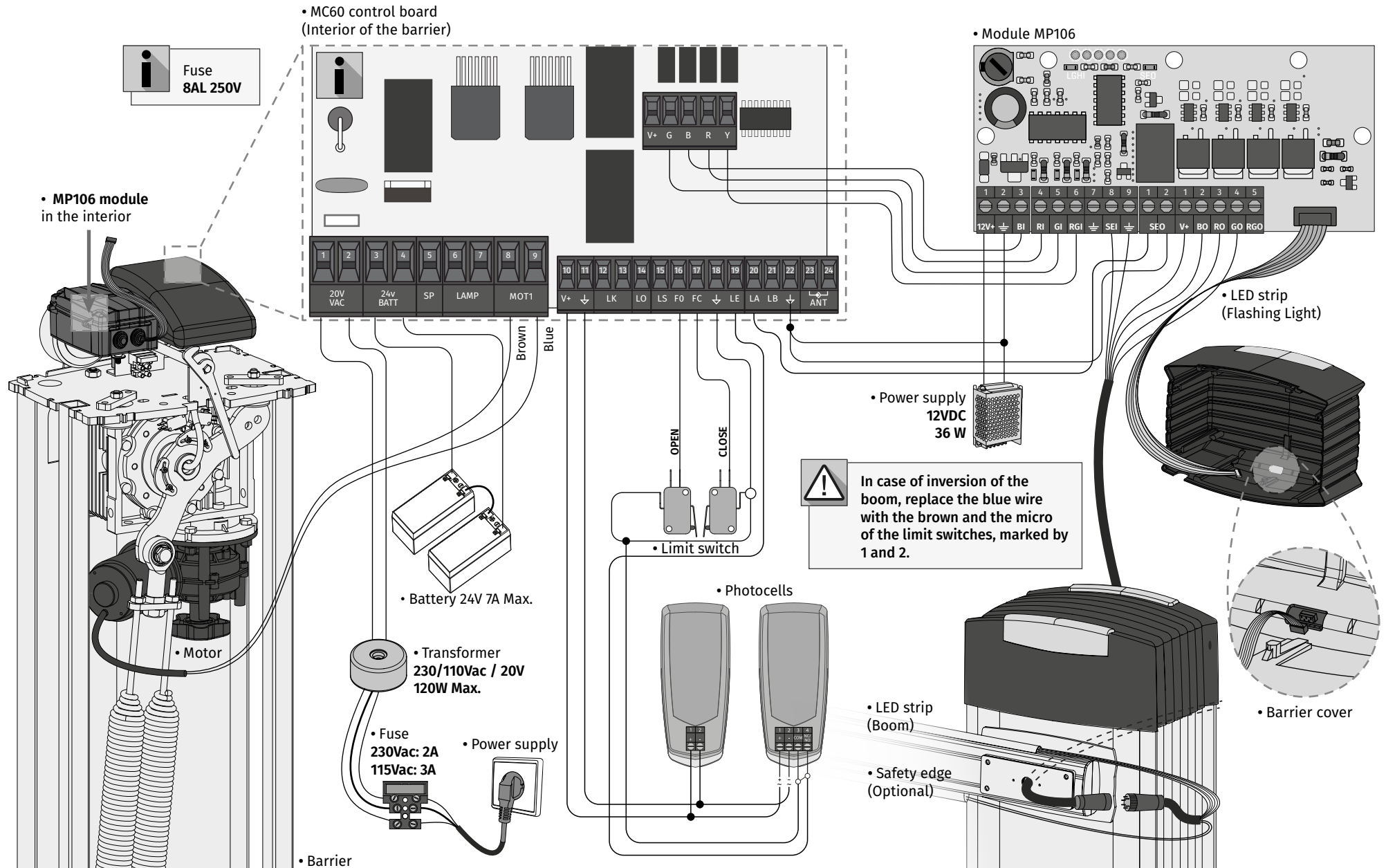

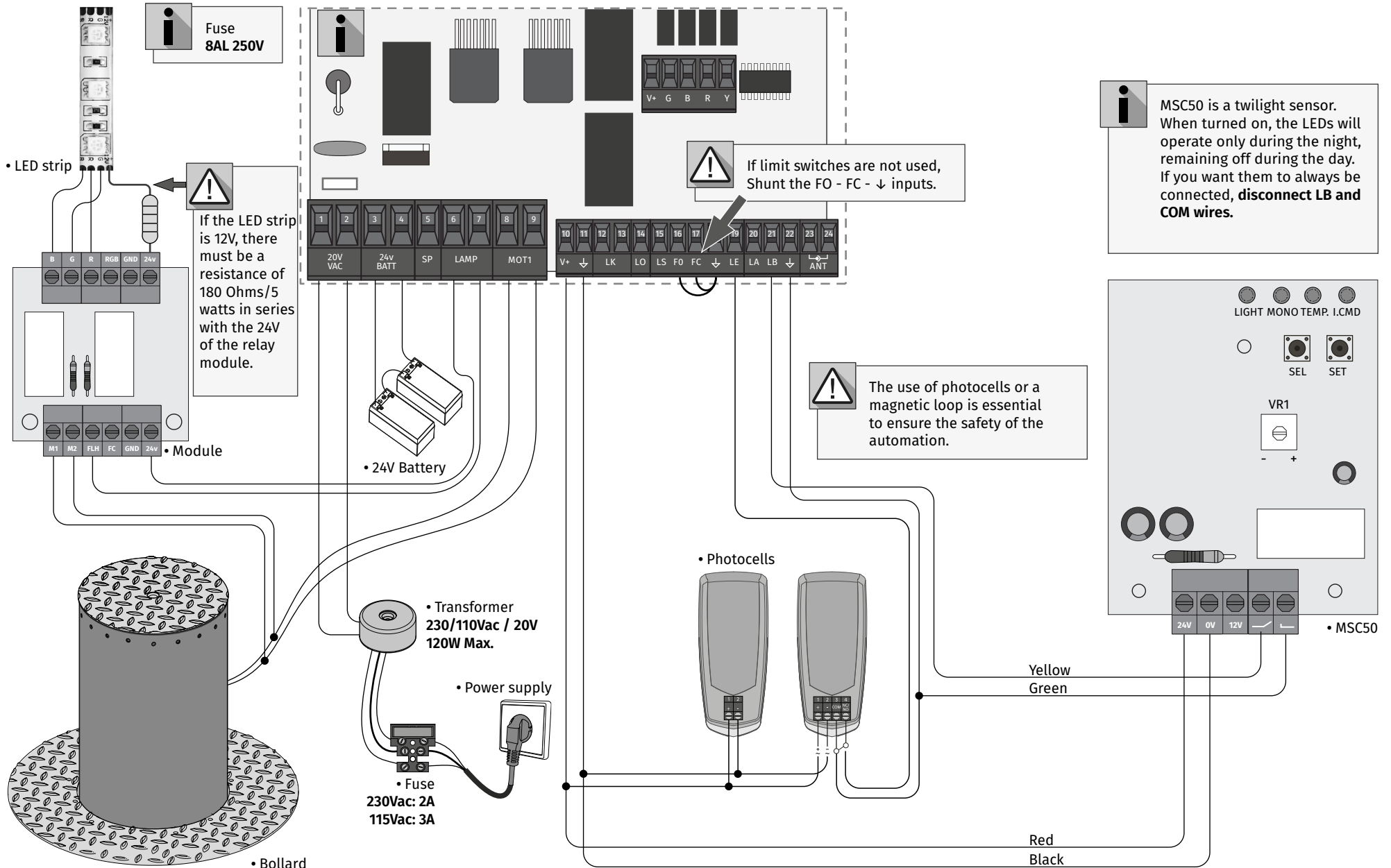



 To use this mode, select the function at P0 (page 14B).
The values are updated automatically.

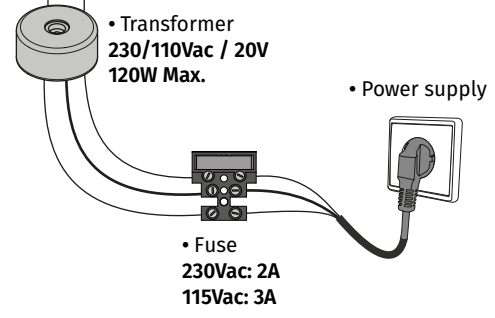
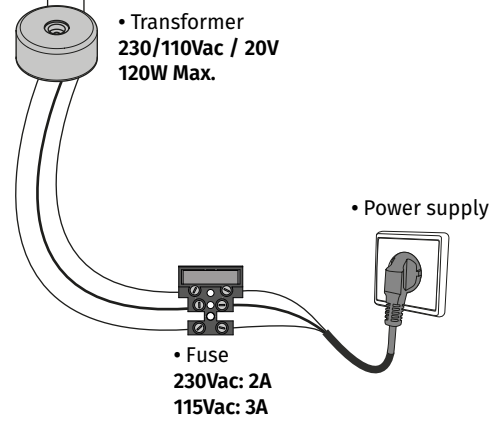
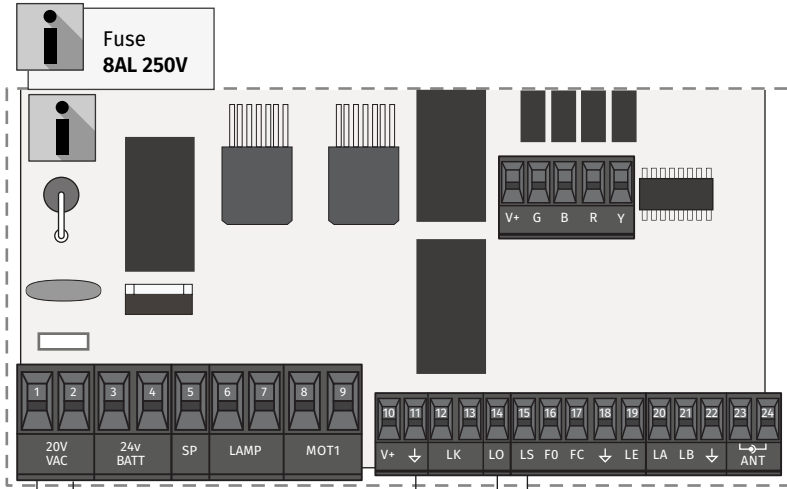
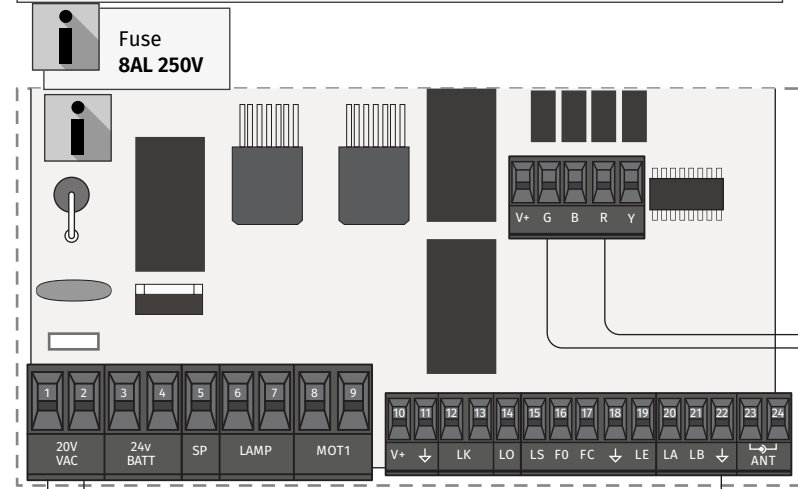



The installation process assumes that the gate already has mechanical or electrical limit switches installed. For more information read the motor's manual.

- 01 • Connect all accessories according to the connections diagram.
- 02 • Connect the control board to a 20V power supply
- 03 • Check if the gate movement is the same as shown on the display:

00

CLOSE

0P

OPEN



If the display does not match the movement of the gate, switch off the power supply center and change the wires of Motor (8 and 9) and check the direction of the limit switches.

- 04 • Make a course programming - menu P0 (page 14B).
- 05 • If necessary, adjust the slowdown time of the gate at opening and closing - menu P1 (page 15A).
- 06 • Adjust the gate force - menu P2 (page 15A).
- 07 • Re-program the course - menu P0 (page 14B).
- 08 • Enable or disable the use of Photocells in menu P5 and P6 (page 16A and 16B).
- 09 • Program a remote control (page 12B).

The control board is now fully configured!
Check the pages of the menu programming if you want to configure other features of the Control board.

SU Remote control programming for total opening.

SP Remote control programming for pedestrian opening.

• PROGRAMMING REMOTE CONTROLS

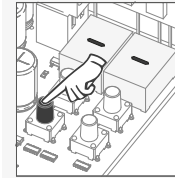

01 • Press the cmd button for 1 sec.

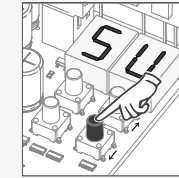

02 • Select the function where you want to program the remote controls (SU or SP) use ↓ ↑.

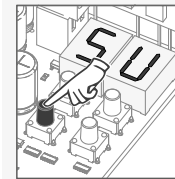

03 • Press cmd once to confirm. (SU or SP).

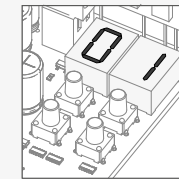

04 • The first free position appears.



05 • Press the remote controls button you want to program. The display will blink and move to the next free location.

• ERASE REMOTE CONTROLS

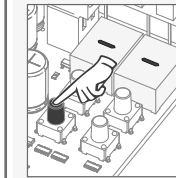

01 • Press the cmd button for 1 sec.

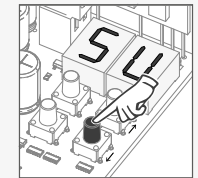

02 • Select (SU or SP) use ↓ ↑.

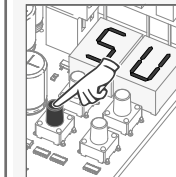

03 • Press cmd once to confirm. (SU or SP).

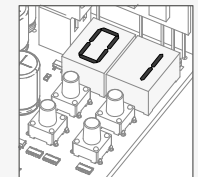

04 • Use ↓ ↑ to select the remote controls location you want to delete.

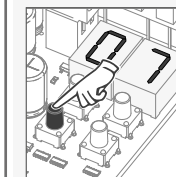

05 • Press cmd for 3 sec and the location will be empty. The display will blink and the position will be free.

• ERASE ALL THE REMOTE CONTROLS

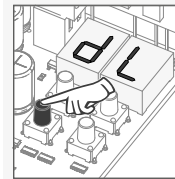

01 • Press the cmd button for 5 sec.
02 • The display will show dL, confirming that all remote controls have been erased.



• Whenever you store or delete a the display will flash and show the next position. You can add or delete remote controls without needing back to point 01.



• If you do not press any button for 10 sec. the control board will return to standby

 We can only go into programming with the gate electrically stumpled.

The functions of the plant are divided into 2 areas:

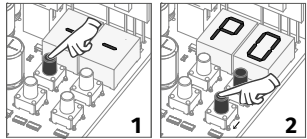

"P" MENU

- 1 • To access the P menu press the MENU button for 1 sec.
- 2 • Use ↓ ↑ to navigate through the menus.
- 3 • Press MENU when you want to confirm access to a menu.
- 4 • Press ↓ ↑ simultaneously to exit programming.

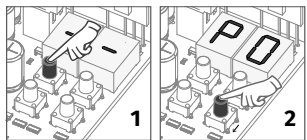
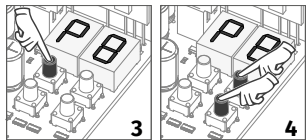

"E" MENU

- 1 • To access the E menu press the MENU button for 5 sec.
- 2 • Use ↓ ↑ to navigate through the menus.
- 3 • Press MENU when you want to confirm access to a menu.
- 4 • Press ↓ ↑ simultaneously to exit programming.

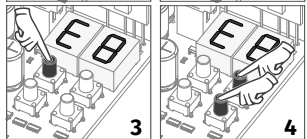

03. INSTALLATION

EXCLUSIVE FACTORY VALUES

MENU	SUB-MENU	SC	SE	BR	PL
P1	Fb	0	0	25	30
P1	Fc	0	0	25	30
P2	Fd	5	5	9	5
P2	Fe	5	5	9	5
P2	Fs	5	5	7	5
P7	-	1	1	2	2
E0	Lb	0	1	0	2
E5	EL	0	1	0	0
E6	So	5	5	2	5
E6	Sc	5	5	1	5

MENU	FUNCTION	MIN.	MAX.	STATE	FACTORY VALUE	PAGE
P0	Course Programming			RU Automatic Programming	sc	14B
				UR Manual Programming		
	System type				Sc Slide gates	
					SE Sectional gates	
					BR Electromechanical barriers	
					PL Bollard	
Master/Slave				00 Master	0	
				01 Slave		
P1	Slowdown time adjustment	0s	9.9s	dR Opening slowdown	See table p.13A	15A
				dF Closing slowdown		
				rO Time ramp at the opening		
P2	Force and sensibility adjustment	0	9	Fb Force Adjustment in Opening	See table p.13A	15A
				Fc Force Adjustment in Closing		
				Fs Sensitivity adjustment		
P3	Pedestrian Course time	0s	99s	Time setting in pedestrian mode	10s	15B
P4	Pause time	0s	99s	RF Full closing pause time adjustment	0s	15B
				RP Pedestrian lock pause time adjustment		
P5	Photocells 1 programming			LE 00 Disables	00	16A
				01 Active		
				HC 00 In Opening		
				01 In Closing		
P6	Photocells 2 programming			HL 00 Invert	00	16B
				01 STOP		
				02 Invert 2 sec. and Stop		
				LR 00 Disables		
P7	Operating logic			01 Active	00	16B
				HC 00 In Opening		
				01 In Closing		
				HL 00 Invert		
P8	Flashing light			01 STOP	00	17A
				02 Invert 2 sec. and Stop		
				HR 00 Disables security band input		
				01 Activates security band input		
P9	Remote programming			00 Automatic mode function	01	16B
				01 Step by step mode		
				02 Condominium mode function		
P8	Flashing light			00 Flashing (opening and closing)	00	17A
				01 Step by step mode		
				02 Courtesy light		
P9	Remote programming			00 Distance PGM OFF	00	17A
				01 Distance PGM ON		

MENU	FUNCTION	MIN.	MAX.	STATE	FACTORY VALUE	PAGE
E0	Human presence	-	-	HP 00 Disables Human presence 01 Active at closing 02 Active during opening and closing	00	17B
				PL 00 Disables push buttons mode 01 Activates push buttons mode	00	
				LB 00 Disables emergency device input 01 Activates input for Emergency 02 Active input for twilight sensor	00	
E1	Soft start	-	-	00 Deactivates Soft start 01 Activates Soft start	00	18A
E2	Courtesy light time	0	99	Courtesy light time adjustment	00	18A
E3	Follow me	-	-	FL 00 Deactivates follow me 01 Activates follow me (fully open) 02 Activates follow me (in open or fully open position)	00	18B
				1s 9s 00 Set closing time (sec)		
E4	Course time adjustment	1m	4m	00 Opening course time (minutes)	00	18B
		0s	59s	05 Opening course time (seconds)	10s	
		1m	4m	00 Closing course time (minutes)	00	
		0s	59s	05 Closing course time (seconds)	10s	
E5	Brake/Lock/-strokes	-	-	EB 00 Disables electronic brake 01 Active electronic brake	00	19A
				EL 00 Activates lock on opening 01 Activates lock with polarity	See table p.13A	
E6	Slowdown Speed	0	9	S0 Adjusting the slowing down at the opening S1 Adjusting the slowing down at the closing	See table p.13A	19A
E7	Maneuvers counter	-	-	Shows the number of maneuvers	-	19B
E8	Reset - Restore factory settings	-	-	00 Deactivated 01 Reset activated	00	20
E9	RGB Output	-	-	00 Continued output 01 Intermittent output	00	20

AU	<p>Automatic course scheduling</p> <p>This menu allows you to automatic motor programming and slowdown.</p> <p></p> <p>To cancel the programming press the UP and DOWN buttons simultaneously. You can use the remote control instead of the MENU button.</p>	<p>Automatic programming:</p> <p>01 • Press MENU for 1 sec. until it appears PO.</p> <p>02 • Press MENU once until it appears AU.</p> <p>03 • Press MENU to start automatic programming. The following maneuvers will be carried out:</p> <p>a • Closes in slowdown</p> <p>b • Opens 4 sec. at normal speed.</p> <p>c • Closes in slowdown</p> <p>d • Fully opens at normal speed.</p> <p>e • Closes 4 sec. at normal speed.</p> <p>f • Opens in slowdown.</p> <p>g • Closes total at normal speed.</p>	
		<p>Manual programming:</p> <p>01 • Press MENU for 1 sec. until it appears PO.</p> <p>02 • Press MENU once until it appears AU.</p> <p>03 • Press UP until it appears PA.</p> <p>04 • Press MENU to start programming the opening time.</p> <p>05 • Press MENU to start programming the slowdown time at the opening.</p> <p>06 • Press MENU to start programming the closing time.</p> <p>07 • Press MENU to start programming the slowdown time at closing.</p> <p>08 • Press MENU to finish programming.</p>	
S2	<p>System type</p> <p>This menu allows you to program the type of system with which the control board will work.</p>	<p>Sliding gates: Emergency device deactivated Deactivate Push button function Opening ramp time at 0 Closing ramp time at 0</p>	<p>Programming system type:</p> <p>01 • Press MENU for 1 sec. until it appears PO.</p> <p>02 • Press MENU once until it appears AU.</p> <p>03 • Press UP until it appears S4.</p> <p>04 • Press MENU to select one of the systems.</p>
		<p>Sectional doors: Emergency device activated Disables func. pushbutton Ramp time at opening to 0 Ramp time at closing to 0 Activates lock with polarity</p>	
		<p>Electromechanical barriers: Emergency device disabled Disables func. pushbutton Ramp time at opening to 25 Ramp time at closing to 25 Activates lock on opening</p>	
		<p>Bollard: Deactivate Push button function Opening ramp time at 30 Closing ramp time at 30</p>	
05	<p>Master/Slave</p> <p>Communication model for hardware devices where one device has one-way control over another device.</p>	<p>00 Master Controls the main functions of the Slave</p>	<p>Programming Master/Slave:</p> <p>01 • Press MENU for 1 sec. until it appears PO.</p> <p>02 • Press MENU until it appears S5.</p> <p>03 • Select 00 or 01.</p> <p>04 • Press MENU to confirm a function.</p>
		<p>01 Slave It is controlled by the Master</p>	

04. PROGRAMMING "P"

P.1 SLOWDOWN TIME ADJUSTMENT

This menu allows to set the slowdown time at opening and closing.

dR	dF
Opening slowdown Allows to set the time that the gate will act with slowdown in the opening. (Default value 3)	Closing slowdown Allows to set the time that the gate will act with slowdown in the closing. (Default value 3)
rO	rC
Time ramp at the opening Allows to set the slowdown ramp time at the opening. (Default value: SC=00; SE=00; BR=25; PL=30)	Time ramp at the closing Allows to set the slowdown ramp time at the closing. (Default value: SC=00; SE=00; BR=25; PL=30)



- 01 • Press MENU for 2 sec. until appears **PO**.
- 02 • Use UP until appears **P.1**.
- 03 • Press MENU will appear **dR**. Use UP or DW to navigate the parameters.
- 04 • Press MENU to edit the chosen parameter value.
- 05 • The factory set time appears. Use UP and DW to change the value.
- 06 • Press MENU to save the new value.

04. PROGRAMMING "P"

P.2 FORCE AND SENSIBILITY ADJUSTMENT

- 01 • Use UP until appears **P.2**.
- 02 • Press MENU will appear **FO**.
- 03 • Press MENU to edit the value.
- 04 • The factory set time appears. Use UP and DW to change the value.
- 05 • Press MENU to save the new value.

04. PROGRAMMING "P"

P.3 PEDESTRIAN COURSE TIME

The pedestrian mode allows the gate to be opened for the passage of people, without it needing to open in its entirety. In this function you can schedule the time you want the gate to open.



For pedestrian mode to work, it is necessary that the minimum work is 1 second, and 0 disables the pedestrian.



- 01 • Use UP until appears **P.3**.
- 02 • Press MENU. The factory set time appears.
- 03 • Use UP and DW to change the value.
- 04 • Press MENU to save the new value.

04. PROGRAMMING "P"

P.2 FORCE AND SENSIBILITY ADJUSTMENT



A very low value in this parameter **F0** or **Fc**, can cause the motor not to have enough torque to move the gate, or **FS** too high.

F0	Fc	FS
Opening force adjustment Allows to set the force that is injected into the opening when the engine moves at normal speed.	Closing force adjustment Allows to set the force that is injected into the closing when the motor moves at normal speed.	Sensibility adjustment Allows to adjust the sensitivity of the motor in the presence of obstacles. The higher the sensitivity, the less effort it will take to detect any obstacle and reverse direction.

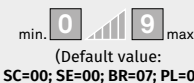
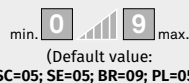

04. PROGRAMMING "P"

P.4 PAUSE TIME

AF	AP
Pause time adjustment for automatic closing This menu allows to set the total opening pause time.	Pause time adjustment for automatic closing in pedestrian closing Allows to set the pause time at the pedestrian opening.



When the values are at zero, there is no automatic closing.

- 01 • Use UP until appears P4.
- 02 • Press MENU will appear RF. Use UP or DW to navigate the parameters.
- 03 • Press MENU to edit the chosen parameter value.
- 04 • The factory set time appears. Use UP and DW to change the value.
- 05 • Press MENU to save the new value.

Allows to program the security behavior LE (photocell 1).

LE	HE	HL
<p>00 (off) 01 (active) Enable or disable security entry.</p>	<p>00 (opening photocells) 01 (closing photocells) This menu can only be changed when the LE menu is active. Allows you to define whether this security will act on the opening or closing of the gate.</p>	<p>00 (the gate is reversed) 01 (gate stops and resumes 5 sec after security is disabled) 02 (gate reverses for 2 sec. and stop) It allows to define the behavior that the gate will have when this security is activated.</p>
(Default value 0)	(Default value 1)	(Default value 0)

- 01 • Use UP until appears P5.
- 02 • Press MENU will appear LE. Use UP or DW to navigate the parameters.
- 03 • Press MENU to edit the chosen parameter value.
- 04 • The factory set time appears. Use UP and DW to change the value.
- 05 • Press MENU to save the new value.

Allows to program the security behavior LA (photocell 2).

LA	HC	HL	HA
<p>00 (off) 01 (active) Enable or disable security entry.</p>	<p>00 (opening photocells) 01 (closing photocells) This menu can only be changed when the LA menu is active. Allows you to define whether this security will act on the opening or closing of the gate.</p>	<p>00 (the gate is reversed) 01 (gate stops and resumes 5 sec after security is disabled) 02 (gate reverses for 2 sec. and stop) Allows to set the behavior that the gate will have when this security is activated.</p>	<p>00 (disables safety edge) 01 (active safety edge)</p>
(Default value 0)	(Default value 0)	(Default value 1)	(Default value 0)

- 01 • Use UP until appears P6.
- 02 • Press MENU will appear LR. Use UP or DW to navigate the parameters.
- 03 • Press MENU to edit the chosen parameter value.
- 04 • The factory set time appears. Use UP and DW to change the value.
- 05 • Press MENU to save the new value.

This menu allows to set the operating logic of the automation

00	01	02
<p>Automatic Mode Whenever there is an order the movement is reversed.</p>	<p>Step by step mode 1st impulse - OPEN 2nd impulse - STOP 3rd impulse - CLOSE 4th impulse - STOP Stopping movement during closing disables automatic closing.</p>	<p>Condominium Mode Does not respond to orders during opening and pause time.</p>

(Default value: SC=01; SE=01; BR=02; PL=02)

- 01 • Use UP until appears P.7.
- 02 • Press MENU will appear 00.
- 03 • Press MENU to edit the value.
- 04 • Use UP and DW to change the value.
- 05 • Press MENU to save the new value.

This menu allows to set the operation mode of the flashing light (LAMP).

00	01	02
<p>Flashing (opening and closing) During the opening/closing movement of the gate, the flashing light will operate intermittently.</p> <p>Opening - flashing 2s Closing - flashing 1s</p>	<p>Step by step mode In the opening and closing movement, the flashing light is permanently ON. When stopped, it remains off.</p>	<p>Courtesy light In the opening and closing movement the flashing light is permanently ON. When in pause time remains ON. When stopped or closed, remains on for the time set in E2.</p>
Default value (00)		

- 01 • Use UP until appears P.8.
- 02 • Press MENU will appear 00.
- 03 • Press MENU to edit the value.
- 04 • Use UP and DW to change the value.
- 05 • Press MENU to save the new value.

00	01
Distance PGM OFF	Distance PGM ON
<p>This menu allows to enable or disable the programming of new remote control without directly accessing the control board, using a previously stored remote control (memorize remote controls page 11B).</p>	
Default value (00)	

- 01 • Use UP until appears P.9.
- 02 • Press MENU will appear 00.
- 03 • Press MENU to edit the value.
- 04 • Use UP and DW to change the value.
- 05 • Press MENU to save the new value.

Remote Programming Operation (PGM ON):



• Press the buttons indicated in the image simultaneously for 10 seconds and the flashing light will flash (the 1st free position appears in the display).
Each time you store 1 remote control, the control board will exit remote programming. If you want to memorize more remote control, you will always have to repeat the process of pressing the remote controls buttons simultaneously for 10 seconds for each new remote control.

HP	PL	LB									
<p>00 (disables human presence) Whenever a order to LS input and the motor performs a complete maneuver.</p> <p>Human presence 01 (active at closing) The motor only works if you keep the LS button pressed.</p> <p>Human presence 02 (active during opening and closing) The motor only runs if you keep the LS button pressed.</p> <p style="text-align: center;"></p> <p>When human presence active, the RF remote controls do not work.</p> <p style="text-align: center;">(Default value 00)</p>	<p>00 (disables pushbutton mode)</p> <p>01 (active pushbutton mode)</p> <table border="1" style="margin-left: auto; margin-right: auto;"> <thead> <tr> <th></th> <th>LS</th> <th>LO</th> </tr> </thead> <tbody> <tr> <td>01 ACTIVE</td> <td>Full closing</td> <td>Full opening</td> </tr> <tr> <td>00 OFF</td> <td>Pedestrian opening</td> <td>Full opening</td> </tr> </tbody> </table> <p style="text-align: center;">(Default value 00)</p>		LS	LO	01 ACTIVE	Full closing	Full opening	00 OFF	Pedestrian opening	Full opening	<p>Allows you to define the way Operation of the LB input</p> <p>00 (disables input to emergency stop device)</p> <p>01 (input for emergency stop)</p> <p>02 (twilight sensor input - outputs for LEDs that run at night and remain out of the day)</p> <p style="text-align: center;">(Default value SC=00; SE=01; BR=00; PL=02)</p>
	LS	LO									
01 ACTIVE	Full closing	Full opening									
00 OFF	Pedestrian opening	Full opening									

- 01 • Press MENU for 5 sec. until it appears E.0.
- 02 • Press MENU will appear HP. Use UP or DW to navigate the parameters.
- 03 • Press MENU to edit the chosen parameter value.
- 04 • The factory set time appears. Use UP and DW to change the value.
- 05 • Press MENU to save the new value.

05. PROGRAMMING "E"

E.1 SOFT START

00 off
01 active

Enables or disables the soft start. With the soft start function activated, at each start of movement the control board will control the motor start, increasing the speed gradually in the first second of operation.

(Default value 01)

- 01 • Use UP until appears **E1**.
- 02 • Press MENU will appear **00**.
- 03 • Press MENU to edit the value.
- 04 • Use UP and DW to change the value.
- 05 • Press MENU to save the new value.

05. PROGRAMMING "E"

E.2 COURTESY LIGHT TIME

Allows to adjust the courtesy light time. The courtesy light is activated the set time when the gate is in the closed, opened and stopped position.

The E2 menu will only be available if the courtesy light function is activated in the P8 menu option 2 (see page 16A).

(Default value 00)

- 01 • Use UP until appears **E2**.
- 02 • Press MENU will appear **00**.
- 03 • Press MENU to edit the value.
- 04 • Use UP and DW to change the value.
- 05 • Press MENU to save the new value.

05. PROGRAMMING "E"

E.3 FOLLOW ME

FL

00 function disabled
01 function activated after opening
02 function activated on opening

Allows you to activate the Follow me option. With this option activated, the control board, when in the open position or in opening, gives a closing order of 5 sec. after the safety device detects the passage of an object / user.

E3

01 - 09 closing time function

Allows setting the closing time (sec) after the safety device detects the passage of an object/user.

(Default value 00)

- 01 • Press MENU for 5 sec. until **E0** appears.
- 02 • Press MENU until **FL** appears. Use UP or DW to navigate parameters.
- 03 • Press MENU to edit the value of the chosen parameter.
- 04 • Choose the desired value. Use UP and DW to change the value.
- 05 • Press MENU to save the new value.

05. PROGRAMMING "E"

E.4 COURSE TIME ADJUSTMENT

Allows to adjust the working time for the opening and closing courses at normal speed

E7	E5	E7	E5
Opening course time (minutes)	Opening course time (seconds)	Closing course time (minutes)	Closing course time (seconds)
(Default value 0)	(Default value 10)	(Default value 0)	(Default value 10)

- 01 • Use UP until appears **E4**.
- 02 • Press MENU will appear **E7**. Use UP or DW to navigate the parameters.
- 03 • Press MENU to edit the chosen parameter value.
- 04 • The factory set time appears. Use UP and DW to change the value.
- 05 • Press MENU to save the new value.

05. PROGRAMMING "E"

E5 BRAKE/LOCK/PUSH

Allows to activate the electronic brake and change the behaviour of the LK output (lock)



Eb	Eb
00 (disables electronic brake) 01 (activates electronic brake)	00 (activates lock at opening 1 sec.) 01 (activates lock with polarity)
Allows you to activate the electronic brake.	Allows you to select how the lock works.
(Default value 0)	(Default value 0)

- 01 • Use UP until appears E5.
- 02 • Press MENU will appear Eb. Use UP or DW to navigate the parameters.
- 03 • Press MENU to edit the chosen parameter value.
- 04 • The factory set time appears. Use UP and DW to change the value.
- 05 • Press MENU to save the new value.

05. PROGRAMMING "E"

E6 SLOWDOWN SPEED

This menu allows you to adjust the slowdown speed.
The higher the level, the faster the slowdown.

S0	S0
Setting of the slowing speed at the opening	Setting of the slowing speed at the closing
Allows you to adjust the slowing speed in the motor opening.	Allows you to adjust the slowing speed in the motor closing.
 min. 0 max. 9 (Default value: SC=05; SE=05; BR=02; PL=05)	 min. 0 max. 9 (Default value: SC=05; SE=05; BR=01; PL=05)

- 01 • Use UP until appears E6.
- 02 • Press MENU will appear S0.
- 03 • Press MENU to edit the value.
- 04 • Use UP and DW to change the value.
- 05 • Press MENU to save the new value.

05. PROGRAMMING "E"

E7 MANUEVERS COUNTER

This menu allows you to view the number of maneuvers performed.
(complete maneuver means opening and closing).

 **Resetting the control board does not clear the maneuver count.**

Example: 13456 maneuvers
01- Hundred thousand / 34- Thousands / 56- Dozens

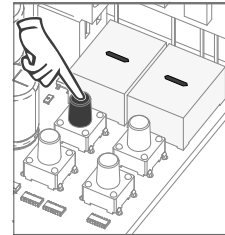

01 • Press MENU for 10 seconds.

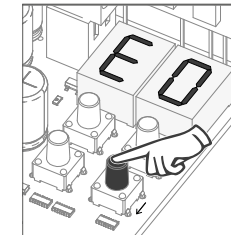

02 • E0 appears.
Press UP until appears E7.

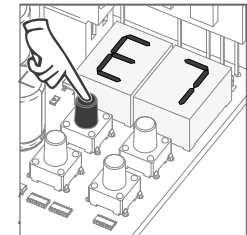

03 • Press MENU.



04 • The maneuvers count is displayed in the following order (example: 130 371)

display flashes



display flashes

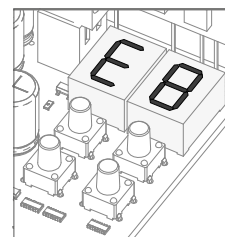

05 • E8 appears.

05. PROGRAMMING "E"

E8 RESET - RESET FACTORY VALUES



Resetting the control board does not erase the maneuver count.

00

00

Disabled

Reset enabled

(Default value 00)

- 01 • Use UP until appears *E8*.
- 02 • Press MENU will appear 00.
- 03 • Press MENU to edit the value.
- 04 • Use UP and DW to change the value.
- 05 • Press MENU to save the new value.

05. PROGRAMMING "E"

E9 RGB OUTPUT

00

00

Continuous light

Flashing light

(Default value 00)

- 01 • Use UP until appears *E9*.
- 02 • Press MENU will appear 00.
- 03 • Press MENU to edit the value.
- 04 • Use UP and DW to change the value.
- 05 • Press MENU to save the new value.

MENU	DESCRIPTION	MENU	DESCRIPTION
88	In stop position, fully open	88	All remote controls erased
88	In stop position, intermediate position	00 01 02	Remote control triggered from the indicated position
88	In stop position, fully closed	0E	Obstructed photocell
00	Full opening button pressed	0A	Obstructed photocell
05	Pedestrian opening button pressed	AF	In pause time
0P	Control board performs the opening course	AP	In pedestrian pause time
00	Control board performs the closing course	91	Motor overcurrent detection
F0	End of opening course time	06	Emergency device activated
F0	End of closing course time	HA	Safety edge pressed
0U	Full memory		

Anomaly	Procedure	Behavior	Procedure II	Discovering the origin of the problem			
• Motor doesn't work.	• Make sure you have power supply connected to automation and if it is working.	• Still not working.	• Consult a MOTORLINE technician.	<p>1 • Open control board and check if it has power supply.</p> <p>2 • Check input fuses of the control board.</p>	<p>3 • Disconnect motor from control board and test it by connecting directly to 12/24V power supply in order to find out if it has the problems.</p>	<p>4 • If the motor work, the problem is on the control board. Pull it out and send it to our MOTORLINE technical services for diagnosis.</p>	<p>5 • If the motor don't work, remove from installation site and send to our MOTORLINE technical services for diagnosis.</p>
• Motor doesn't move but makes noise.	• Unlock the motor and move the gate/barrier/automatic bollard by hand to check for mechanical problems.	• Encountered problems?	• Consult a qualified technician in gate/barrier/automatic bollard.	Check all motion axis and associated motion systems related with the gate/barrier/automatic bollard (rails, pulleys,	bolts, hinges, etc) to find out what is the problem.		
		• The gate/barrier/automatic bollard moves easily?	• Consult a MOTORLINE technician.	<p>1 • If the motors work, the problem is with control board. Pull it out and send it to our MOTORLINE technical services for</p>	<p>diagnosis.</p> <p>2 • If the motor don't work, remove it from installation</p>	<p>site and send to our MOTORLINE technical services for diagnosis.</p>	
• Motor open but doesn't close.	• Unlock the motor and move the gate/barrier/automatic bollard by hand to closed position. Block the motor again. Turn off power supply for 5 seconds, and reconnect. Send order to open using remote control.	• The gate/barrier/automatic bollard opened but didn't close again.	<p>1 • Check if there is any obstacle in front of the photocells.</p> <p>2 • Check if any of the control devices (Key Selector, Pushbutton, Video Intercom, etc.) are stucked and sending permanent signal to control board.</p> <p>3 • Consult a MOTORLINE technician.</p>	<p>All control boards MOTORLINE have LEDs that easily allow to conclude which devices are with anomalies. All safety devices LEDs (Le) in normal situations remain On. All "START" circuits LEDs in normal situations remain Off.</p> <p>If LEDs devices are not all On, there is some security systems malfunction (photocells, safety edges). If "START" circuits LEDs are turn (Op and Cl), there is a control device sending permanent signal.</p>	<p>A) SECURITY SYSTEMS:</p> <p>1 • Close with a shunt all safety systems on the control board (check manual of the control board in question). If the automated system starts working normally check for the problematic device.</p> <p>2 • Remove one shunt at a time until you find the malfunction device.</p> <p>3 • Replace it for a functional device and check if the motor works correctly with all the other devices. If you find another one</p>	<p>defective, follow the same steps until you find all the problems.</p> <p>B) START SYSTEMS:</p> <p>1 • Disconnect all wires connected to the START connector (LO and LS).</p> <p>2 • If the LED turned OFF, try reconnecting one device at a time until you find the defective device.</p> <p>NOTE: In case procedures described in sections A) and B) don't result,</p>	<p>remove control board and send to our MOTORLINE technical services for diagnosis.</p>
• Motor doesn't make complete course.	• Unlock the motor and move the gate/barrier/automatic bollard by hand to check for mechanical problems.	• Encountered problems?	• Consult a qualified technician in gate/barrier/automatic bollard.	Check all motion axis and associated motion systems related with the gate/barrier/automatic bollard (rails, pulleys,	bolts, hinges, etc) to find out what is the problem.		
		• The gate/barrier/automatic bollard moves easily?	• Consult a MOTORLINE technician.	<p>1 • If the motor doesn't work, remove it from installation site and send to our MOTORLINE technical services for diagnosis.</p> <p>2 • If motor work well and move gate at full force during the entire course, the problem is with control board. Set force using trimmer on the board. Make a new working time programming, giving sufficient</p>	<p>time for opening and closing with appropriate force.</p> <p>3 • If this doesn't work, remove control board and send it to MOTORLINE technical services.</p> <p>NOTE: Setting force of the control board should be suficiente to make the gate open and close without stopping, but should stop and</p>	<p>invert with a little effort from a person. In case of safety systems failure, the gate shall never cause physical damaged to obstacles (vehicles, people, etc.).</p>	